

# AFA Systems

Packaging Automation

## AF-RPP Reciprocating Pick and Place Feeder



The servo driven AF-RPP provides customers with an efficient and ergonomic pick and place feeder. It's unique dual head pinch gripper™ can be designed to handle a wide variety of trays, clam shells, coupons, cards and applications unique to your project. The dual head feeder can also allow the AF-RPP to reach speeds of over 100 units per minute and have accurate picks and placements. The AF-RPP can be designed to be stand alone units or be integrated into existing production lines. Changeovers can be completed in under five minutes with the use of adjustable screws. Stainless steel construction comes standard with the AF-RPP.

### Features

- » Wash down construction allows for easy cleaning and maintenance
- » No tool adjustment to assist in changing over from one tray to another which increases productivity
- » Compact design can save a production floor valuable space and provide flexibility
- » Short lead time and can easily integrate into a new or existing production line
- » Full guarding with safety interlocks
- » Quick and simple changeover
- » Casters provide stability



## Typical Floor Plan

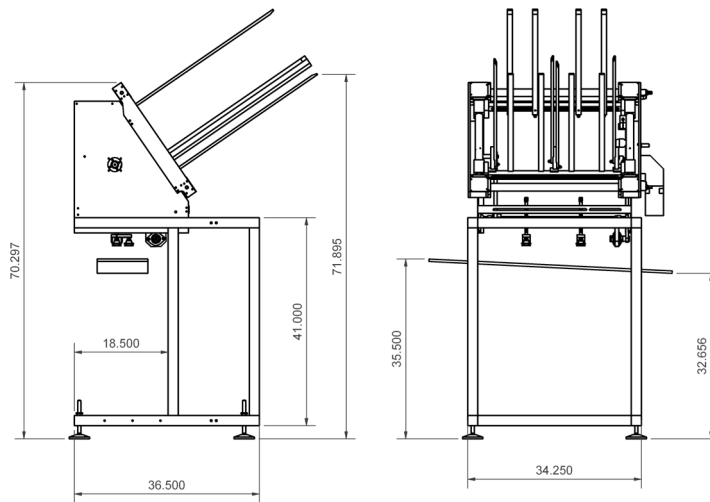

## Key Components

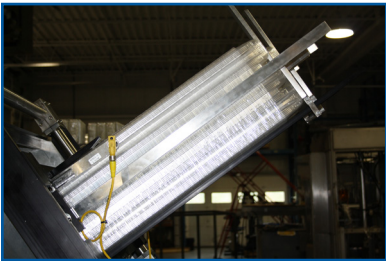

Easy loading magazine for operators. Adjustable screws on magazine allows trays to be changed over in minutes which increases productivity and lowers costs.



Allen Bradley control panel offers simplicity in operation and troubleshooting. In addition, the operator can effectively manage the tray denestor's speed.

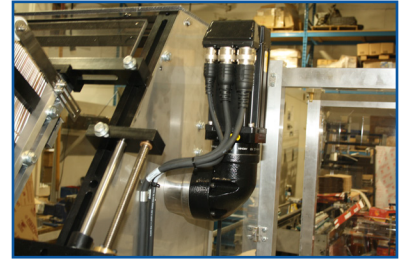

Servo drive attached to tray denestor aids in accurate feedback on positioning and fault diagnostics. In addition, the use of servo's significantly reduces the size of the tray denestor.

## Tray Size Range

Tray size range is application dependent. Please contact an AFA Systems Representative for more information.



## Process

